



THE CONNECTICUT STATE UNIVERSITY

P.O. Box 2008 • New Britain, Connecticut 06050 • (203) 827-7700

RESOLUTION

concerning

ESTABLISHMENT OF EXTENSION FUNDED POSITION
DIRECTOR OF THE ADVISING CENTER/ADMINISTRATOR V

at

EASTERN CONNECTICUT STATE UNIVERSITY

September 5, 1986

RESOLVED, That an Extension Funded position, Director of the Advising Center/Administrator V, be established at Eastern Connecticut State University, effective July 18, 1986, in accordance with all provisions and expectations as set forth in the Addendum attached to this Resolution.

A Certified True Copy:

Dallas K. Beal
President

CSU-200



THE CONNECTICUT STATE UNIVERSITY

P.O. Box 2008 • New Britain, Connecticut 06050 • (203) 827-7700

Submitted	_____
Date	_____
By: CSU ()	
CCSU ()	SCSU ()
ECSU (X)	WCSU ()

POSITION ACTION REQUEST

POSITION ACTION: ESTABLISH (XX) RECLASSIFY () OTHER () DATE EFFECTIVE 7/18/06 PERM (X) FT (X)
 TEMP () FT ()

POSITION TITLE: _____ (Class Code) PROPOSED _____ (Class Code)
 (SU Adm. V - Dir. of Advising Center) Ad. 5 7921

POSITION NUMBER: _____ CURRENT SALARY _____ PROPOSED SALARY \$31,000.00 FUND Ext. _____ BARG UNIT _____ SUOAT from to
 CURRENT SALARY _____ PROPOSED SALARY (\$2,526.00)

RESOLUTION

BR# _____

RESOLVED,

That the position, Director of the Advising Center/Ad. 5 be established at Eastern Connecticut State University.

A Certified True Copy _____

Dallas K. Beal, President, CSU

Date _____

PERCommittee _____

Date _____

BOARD OF TRUSTEES _____

Date _____

JUSTIFICATION: (Use Reverse Side If Additional Space Is Needed)

Eastern is establishing an advising center to provide a central focus for its academic support to students. It is expected that the center will become a focal point in university efforts to aid retention and provide a more focused program for student matriculants. In addition to the director position, the center will be staffed by residence hall directors and three faculty coordinators who will be granted released time.

\$31,000.00 (\$42,526.00)

Approx. Cost

EASTERN CONNECTICUT STATE UNIVERSITY

POSITION DESCRIPTION

POSITION TITLE: Director of the Advising Center

ADMINISTRATIVE RANK: 5

Under the supervision of the Vice-President for Academic Affairs, the Director of the Advising Center is responsible for the operation of the University Advising Center including the supervision and evaluation of all staff and center activities. Responsibilities also include:

1. Administers faculty advisement for all undeclared majors.
2. Conducts intrusive advising activities.
3. Directs a clearing house operation for the dissemination of all academic information.
4. Administers the process of hearing student academic appeals.
5. Maintains effective liaison with academic deans, departmental faculty advisors and student affairs staff.
6. Provides campus wide leadership in developing innovative advising and retention programming.
7. Coordinates various special academic advising programs.
8. Develops grant proposals to obtain outside funding assistance to support the center.
9. Recommends policies and procedures to insure that center activities keep pace with changes in the field.
10. Performs duties related to those listed above which do not alter the overall responsibility level of the position.

QUALIFICATIONS

At least four years experience in learning/education assistance programs in an institution of higher education. Previous experience in teaching and/or grant development desired. Masters degree is required.

These qualifications may be waived for individuals with appropriate alternate experience.

VICE-PRESIDENT FOR ACADEMIC AFFAIRS

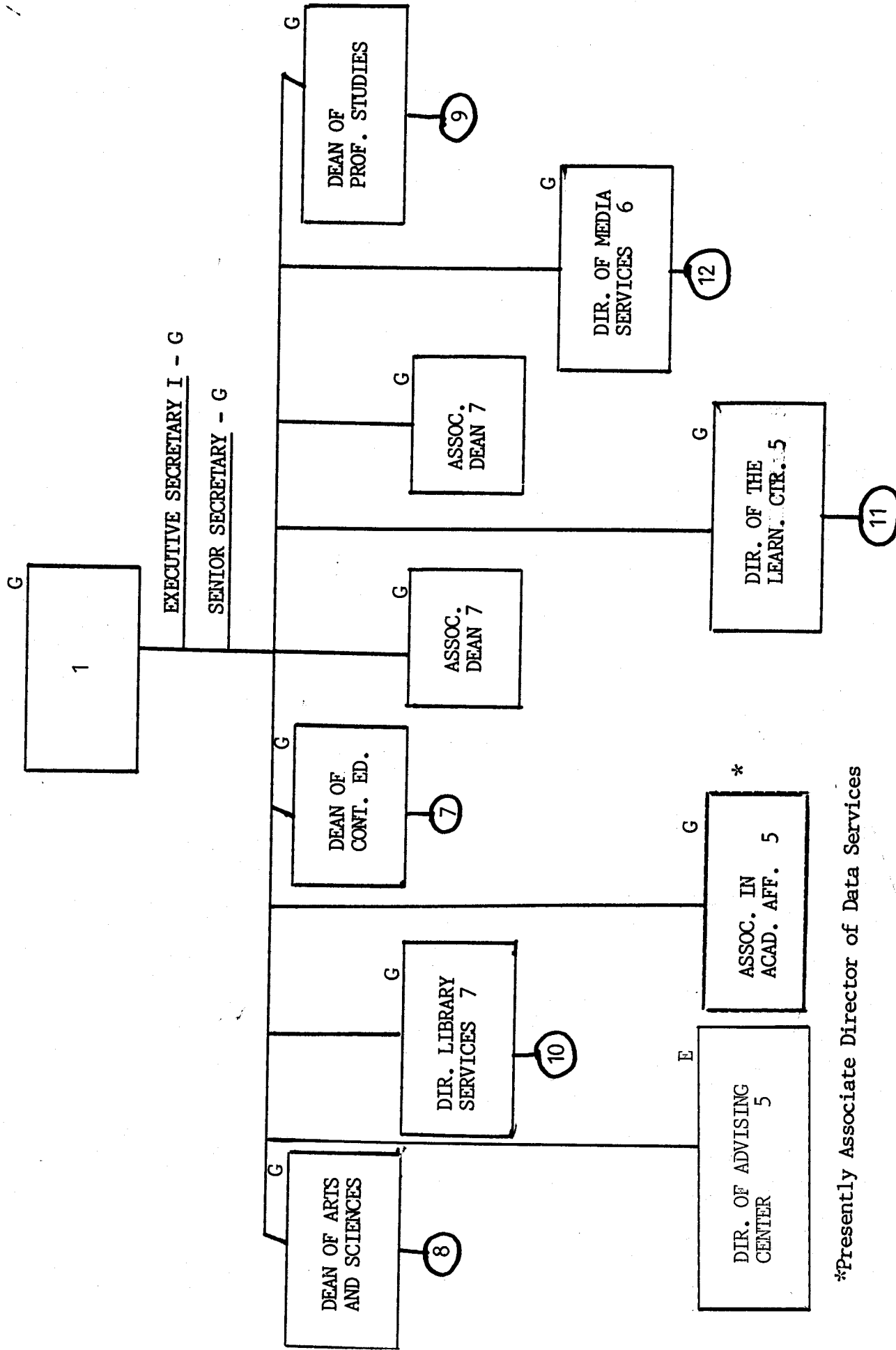

*Presently Associate Director of Data Services